

Forming-, Filling- and Sealing Machine

for smoke-free filter portion packs with oral tobacco
-2 independent stations-



MERZSYSTEM

Verpackungsmaschinen

SB53-2T

Operative range:

- ◆ SMALL STICKPACK-
PORTION PACKAGES
IN FILTER FOIL

Range of products:

- ◆ „Dry tobacco“
containing < 36% of moisture
- ◆ „Wet tobacco“
containing > 36% of moisture
- ◆ „All White“
3% - 55% of moisture content

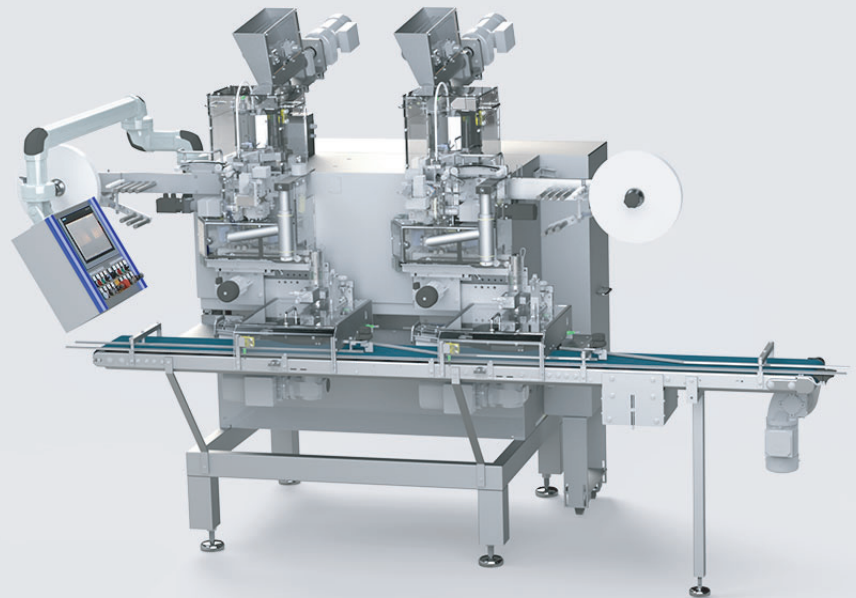

Photo deviating from standard version



„DRY TOBACCO“

Dry tobacco
Will possibly be moisturized
after packaging



„WET TOBACCO“

Humid tobacco containing
more than 36 % of moisture
- With or without moistening
down the line



„All White“

Nicotine powder
containing 3% - 55% of moisture



Forming-, Filling- and Sealing Machine

Type: SB53-2T

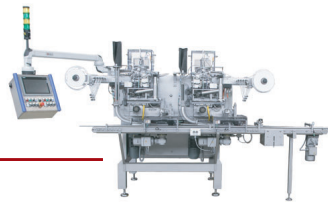

Description of operation:

The packaging machine SB53-2T is a vertically operating, fully automatic forming-, filling- and sealing machine for the production of very small tubular bags, the so called "Stickpacks". The machine processes different types of fleece from the flat foil reel.

In a sequence of single operations, the film is drawn off from the reel, formed to a tube during transportation and sealed lengthwise, filled then, sealed transversally and cut off.

The SB53-2T is a machine with 2 lanes in one housing.

Technical Data:

Bag width standard	12 / 14 / 18 mm
Special bag width	on request
Bag length	min. 30mm max. 38mm
Special bag length	up to 41 mm
Filling volume per bag	approx. 0,2 - 1,2 g adjustable
Output bags/min	Output bags/min
Number of lanes	2 lanes, independent
Diameter of film reel	max. 400 mm
Diameter of film reel core	70/76 mm
Sealing pressure	up to 1000 N
Air connection	6 bar
Electr. connected wattage	approx. 5 KW
Voltage supply standard	400V/3/N/PE/50Hz
Protection class	IP 54
Weight	approx. 1200 kg
Colour standard	stainless steel - alu
Packaging material	

Technical Details:

- ◆ Machine made of stainless steel
- ◆ Siemens PLC
- ◆ Foil monitoring (end + tear)
- ◆ Servo drive continuous foil transport unit
- ◆ Sealing pressure mechanical + pneumatic spring
- ◆ Filling amount adjustable
- ◆ Moistening of Sticks adjustable
- ◆ Product monitoring + automatic refill
- ◆ -Stop- when need of product or foil
- ◆ Display of all malfunctions
- ◆ Output continuously adjustable (electromechanically)
- ◆ Counting of sticks for boxes
- ◆ Box handling automatically
- ◆ Quick exchange forming set

Options:

- ◆ Box and lid supply
- ◆ Can closing unit
- ◆ Labelling
- ◆ Check weighing
- ◆ Box end packaging (shrinking)
- ◆ Special design:
 - ◆ Complete line with up to 4 double machines
 - ◆ Allen Bradley PLC

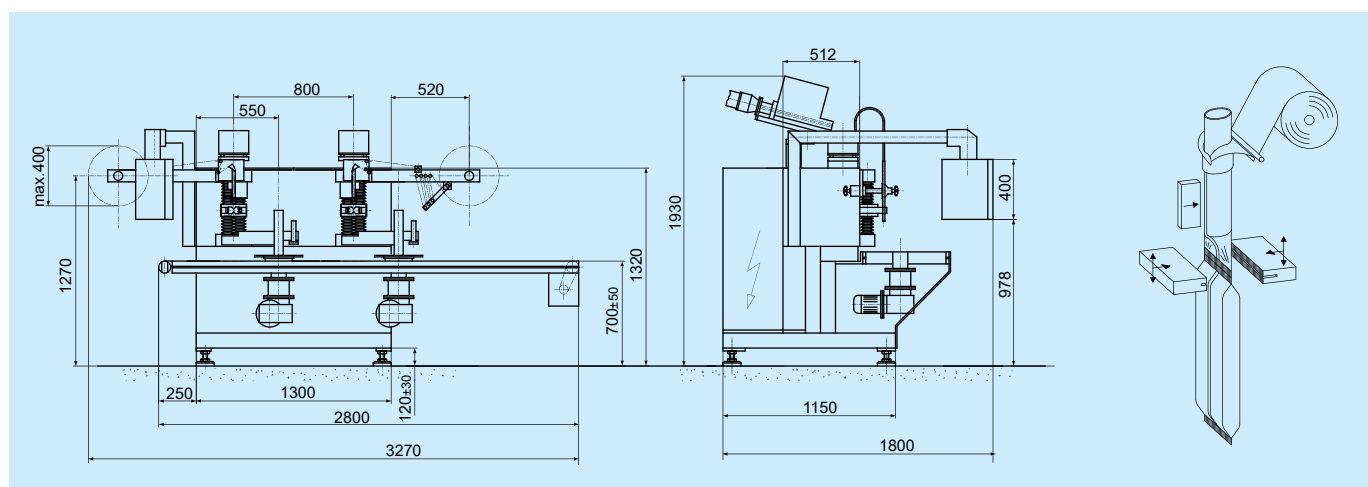
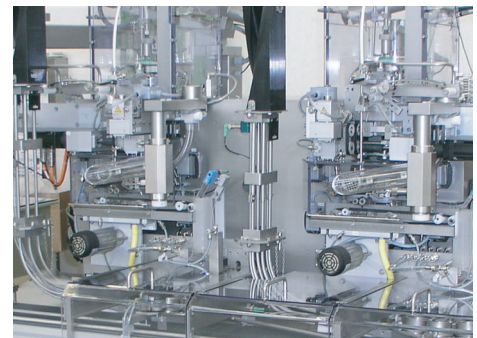

Since 1971 Made in Germany